

# Polarization-Multiplexed 2.8 Gbit/s Synchronous QPSK Transmission with Real-Time Digital Polarization Tracking

T. Pfau (1), R. Peveling (1), F. Samson (1), J. Romoth (1), S. Hoffmann (1), S. Bhandare (1), S. Ibrahim (1), D. Sandel (1), O. Adamczyk (1), M. Pormann (1), R. Noé (1), J. Hauden (2), N. Grossard (2), H. Porte (2),

D. Schlieder (3), A. Koslovsky (3), Y. Benarush (3), Y. Achiam (3)

1 : Univ. Paderborn, EIM-E, Warburger Str. 100, D-33098 Paderborn, Germany

pfau/hoffmann/bhandare/ibrahim /sandel/adamczyk @ont.upb.de, noe@upb.de,

ralf.peveling/florian.samson/johannes.romoth/mario.pormann@hni.upb.de

2 : Photline Technologies, hauden/grossard/porte@photline.com

3 : CeLight Israel, dschlieder/akoslovsky/ybenarush/yachiam@celight.com

**Abstract** This paper presents the implementation of an electronic polarization tracking algorithm which enables real-time polarization-multiplexed synchronous QPSK transmission with DFB lasers. The achieved BER at 2.8 Gbit/s is well below the FEC threshold.

## Introduction

The interest of utilizing existing fiber links most efficiently has recently directed a lot of research towards multilevel phase modulation schemes. In particular, synchronous QPSK transmission promises ultimate performance and dispersion tolerance in upgraded or newly built fiber links. In combination with polarization multiplex it quadruples channel capacity compared to single-polarization OOK transmission. However a compensation circuit is required on the receiver side to separate the two mixed polarizations. An analog compensation circuit with manual control has successfully been employed [1], but it is preferable to have an automatic polarization control integrated into the intradyne digital receiver [2]. It allows recovering the carrier, controlling polarization inside a polarization diversity receiver, and compensating dispersion electronically. Many offline experiments have already shown the potential of this modulation scheme [3-6].

In this paper we demonstrate, as a result of the European research project "synQPSK", the implementation of a real-time electronic polarization tracking algorithm which enables robust polarization-multiplexed QPSK transmission with standard DFB lasers.

## Polarization-multiplexed QPSK setup

Four precoded 700 Mbit/s bit streams ( $2^{31}-1$  PRBS, decorrelation of I&Q by 64 bit, decorrelation of polarizations by 7 bit) modulate the signal of a DFB laser in two QPSK modulators [7] to generate a 2.8 Gbit/s polarization-multiplexed QPSK signal (Fig. 1). After transmission over 120 km of standard single-mode fiber, the signals are received in a polarization diversity coherent optical receiver with two integrated-optical  $90^\circ$  hybrids [8]. Subsequent to an analog-to-digital conversion, a purely electronic manipulation of an electronic equivalent of the optical field vector is undertaken in a field-programmable gate array to separate the two polarizations. Finally, a

feedforward scheme recovers the optical carrier in spite of the 2 MHz sum laser linewidth. Two different filters with phase estimation interval  $2 \cdot (2N+1)$ ,  $N \in \{2, 4\}$  are used to demodulate the four data streams synchronously and examine the influence of the filter width on the bit error rate [9].  $N$  is the number of considered samples in each polarization before and after the sample whose phase is to be estimated. Correlation of data before and behind the decision circuits is used to update the elements of the matrix which transforms the mixed-polarization electronic field vector. The principle is described in [10]. However, a real  $4 \times 4$  matrix is used, onto which a polarization-mixed real vector  $[I_1, Q_1, I_2, Q_2]$  is multiplied to obtain a polarization-separated one. This allows to automatically equalize I&Q amplitudes and phase differences. The control time constant  $(1/e)$  is 12  $\mu$ s.

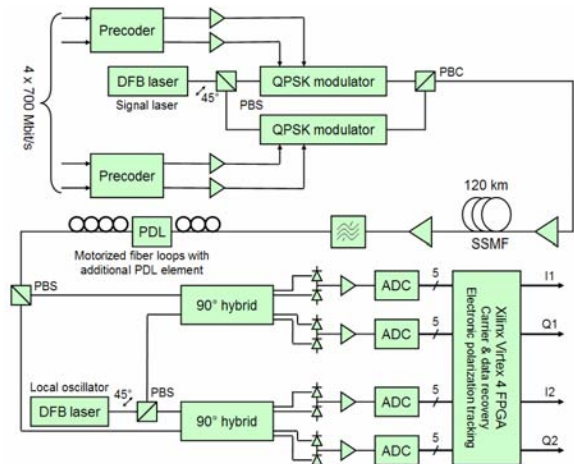

Fig. 1: Setup for 2.8 Gbit/s polarization multiplexed synchronous QPSK transmission

To recover the clock from the NRZ signal, I and Q signals of one polarization are sampled also with an inverted clock signal in additional ADCs. After temporal alignment in the FPGA, these samples are correlated with the adjacent regular ones, and the

results are subtracted to obtain the clock phase error signal. This error signal is input into the clock recovery PLL. Two additional error signals are also generated inside the FPGA, and used to control EDFA gain and LO frequency.

### Measurement results

Fig. 2 shows the measured BER vs. optical power at the preamplifier input of the receiver after transmission over a distance of 120 km. For better readability the averaged BERs are shown, because there were only minor differences between the BERs of the four output bit streams. The best measured BERs were  $2.1 \cdot 10^{-6}$  and  $1.0 \cdot 10^{-4}$  for the filters with  $N = 2$  and  $N = 4$ , respectively. Afterwards a motorized fiber-loop polarization scrambler causing endless polarization changes at a speed of up to 50 rad/s and an element with a polarization dependent loss (PDL) of 3 dB were inserted in the transmission link. This caused the signal to be highly time-variant and degraded the minimum BER values to  $2.8 \cdot 10^{-5}$  for  $N = 2$ , and  $1.7 \cdot 10^{-4}$  for  $N = 4$ . For lower preamplifier input powers, where ASE noise is dominant, there was no distinguishable BER degradation. All recovered bit streams could be synchronized to the transmitted patterns until the preamplifier input power was set below -51 dBm.

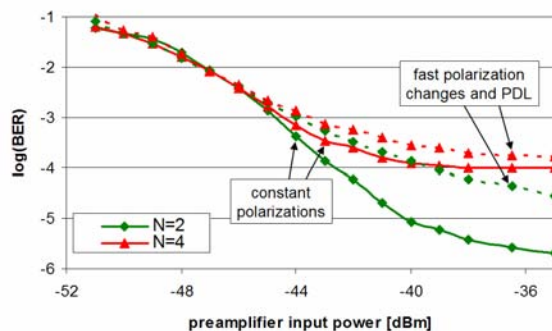

Fig. 2: Measured BER vs. preamplifier input power for a data rate of 2.8 Gbit/s.

Fig. 3 shows BER variations in one polarization over a time frame of 10 minutes for two different preamplifier input power levels with counting intervals of 10 seconds. Only slight BER fluctuations were measured, although the polarization states changed rapidly due to the fiber loop scrambler and the 3 dB PDL element.

### Discussion

Already at a line rate of only 0.7 Gbit/s the implemented polarization tracking algorithm can follow fast fluctuations of the polarization states. The results shown in Fig. 3 clearly demonstrate the reliability and robustness of the system. The matrix was updated using the information of only 1 out of 8 parallel modules. Together with a potential symbol

rate increase to 10 Gbaud a substantially reduced control time constant seems feasible.

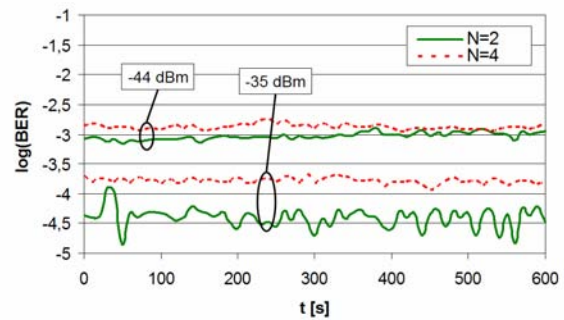

Fig. 3: BER (I&Q averaged) in one polarization vs. time for two preamplifier input powers and filter types.

Concerning the compared filter version, the phase estimation with the lower effort ( $N = 2$ ) yields better BERs than the version with  $N = 4$ . It is notable that  $N = 2$  is advantageous over the whole measurement range. However, we assume that for higher bit rates the filter version with  $N=4$  will be advantageous, as the linewidth times symbol rate product will decrease.

### Conclusions

We have demonstrated real-time electronic polarization tracking in a polarization-multiplexed coherent optical synchronous quadrature phase shift keying transmission system at a data rate of 2.8 Gbit/s. With a PDL of 3 dB and severe endless polarization changes at a speed of up to 50 rad/s, a bit error ratio of  $2.8 \cdot 10^{-5}$  was achieved, which is well below the FEC threshold. For low OSNR values the BER performance under rapid polarization tracking does not differ from the case of constant input polarization states.

### References

- 1 S. Calabrò et al, Proc. ECOC2003, Th2.2.2, Sept. 21-25, 2003 Rimini, Italy.
- 2 R. Noé, IEEE JLT, Vol. 23 (2005), pp. 802-808
- 3 S. Tsukamoto et al, Proc. OFC/NFOEC2005, PDP29, March 5-10, 2005, Anaheim, CA, USA.
- 4 C. Fludger et al, Proc. ECOC2006, Th4.3.3, Sept. 24-28, 2006, Cannes, France
- 5 C. Laperle et al, Proc. OFC/NFOEC2007, PDP16, March 25-29, 2007, Anaheim, CA, USA.
- 6 G. Charlet et al, Proc. OFC/NFOEC2007, PDP17, March 25-29, 2007, Anaheim, CA, USA.
- 7 H. Porte et al, Journée Optique et Micro-onde, Rouen, March 24, 2006
- 8 P. Cho et al, Proc. OAA/COTA2006, CThB2, June 25-30, 2006, Whistler, Canada.
- 9 S. Hoffmann et al, Proc. OAA/COTA2006, CThC6, June 28-30, 2006, Whistler, Canada.
- 10 R. Noé, IEEE PTL, Vol. 17 (2005), pp. 887-889.